

# AIR SWITCH

## TWO FUNCTIONS IN ONE:

### 1) A SNAP ACTION SWITCH

For Precise Direct Control of Pneumatic Systems, Increasing Reliability, Simplifying Circuitry and Thriving in Adverse Environments.  
(For replacing electrical Micro® type switches with pneumatic switches.)

### 2) A RUGGED 4-WAY VALVE

With full 1/4" flow (Cv=1) and ultra-high speed response. Shear type, lapped and hardened stainless steel seal surfaces make valve absolutely leak proof and provide long trouble-free life. Pressure range: 0 -150 P.S.I air only. Vacuum: Consult factory.

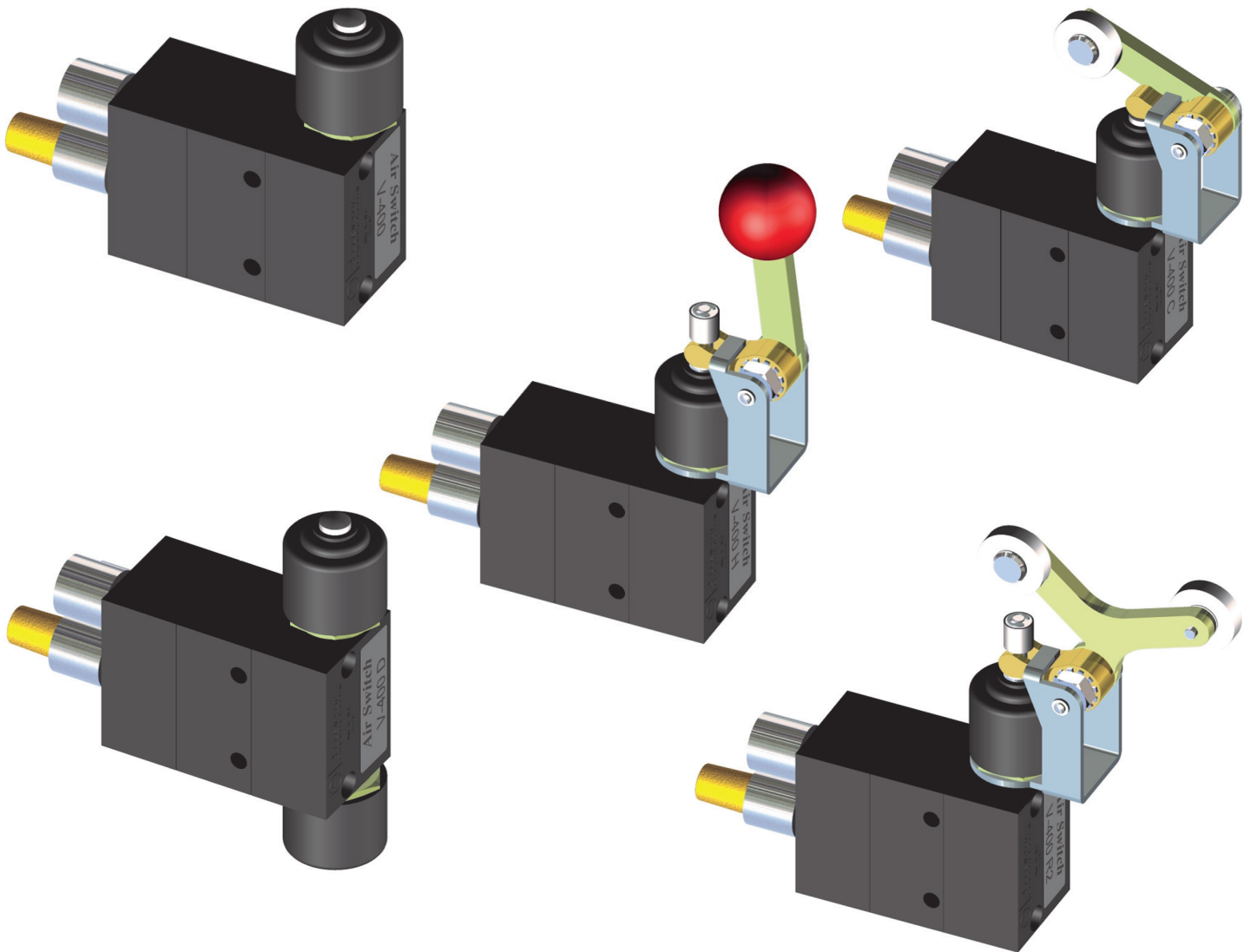

## TYPICAL APPLICATIONS

### DIRECT CONTROL OF LARGE CYLINDERS

Valve will stroke a 4" x 6" Cylinder in 1/6 of a second at 100 P.S.I, using a quick exhaust, 1/3 of a second exhausting through valve. No switches, solenoids, electric or pilot circuitry to install and maintain.

### PRECISE SENSING

Actuator position has a repeatability of less than  $\pm 0.001$  for superior accuracy in control system.

### PROGRAM MODULE

Valves may be easily stacked to centralize controls, save space, simplify piping and engineering, highly suited to automated operations.



# AIR SWITCH

## MODEL (CONTINUED)

### ONE WAY ROLLER

#### V400R

Actuates by Cam Depressing Roller from one Direction only. Roller Displaces without actuation in other Direction.

Actuating Force Required 4 lbs.

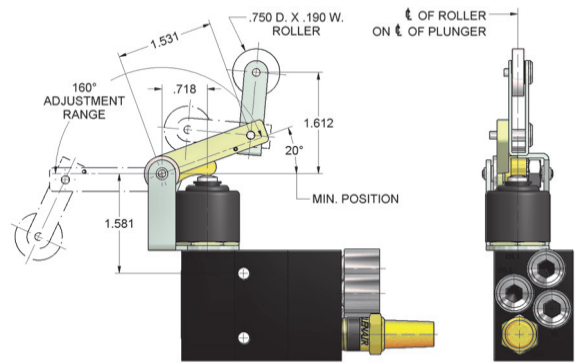
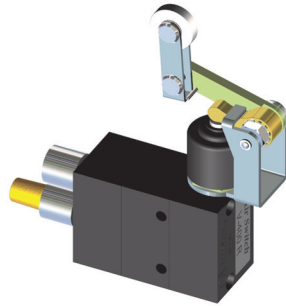

### TWO WAY YOKE ROLLER

#### V4002R

Actuates by Cam Depressing Roller On movement to either side from Center.

Actuating Force Required 2 lbs.

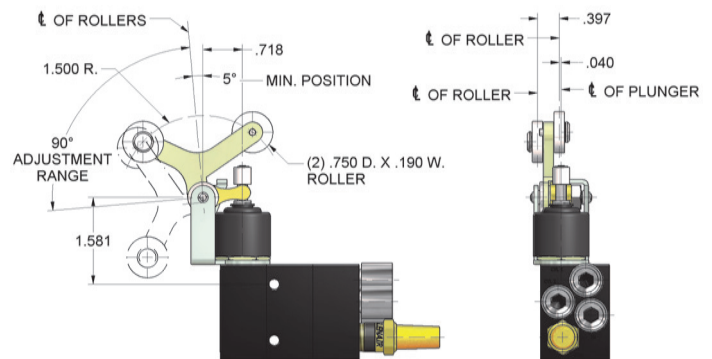
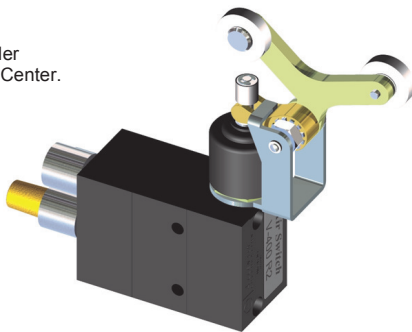

### PALM LEVER, SPRING RETURN

#### V400P

Actuates by Depressing Lever. Returns to normal position by spring.

Actuating Force Required 4lbs.

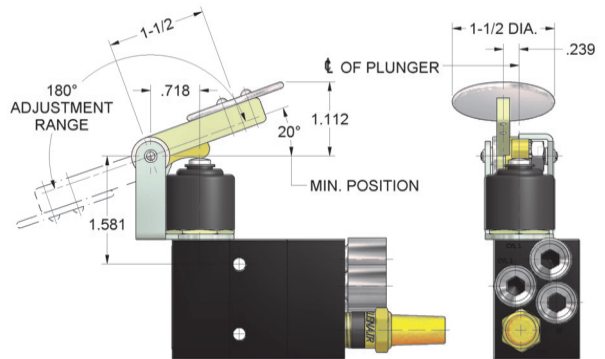
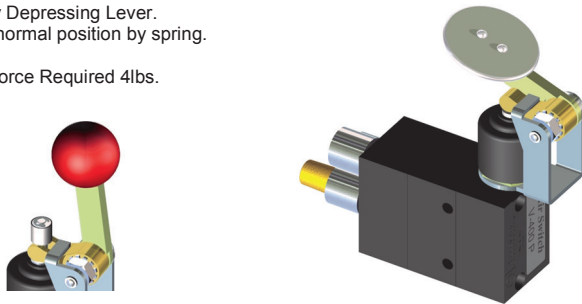

With knob.  
Order as V400PH

### HAND LEVER

#### V400H

Actuates by Offsetting Lever. Remains in offset once shifted.

Actuating Force Required 2 lbs

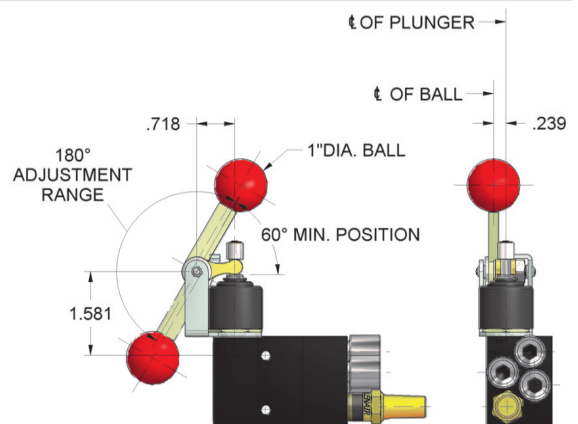
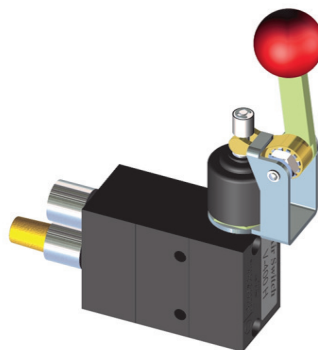

NOTE: ALL ACTUATOR BRACKETS ROTATABLE 360 DEGREES ABOUT  $\uparrow$  OF PLUNGER

## MOUNTING BRACKETS

(Order Separately)

These Brackets adapt Valves directly to existing electric (Micro-type®) switch locations

### WM-400 WALL MOUNTING

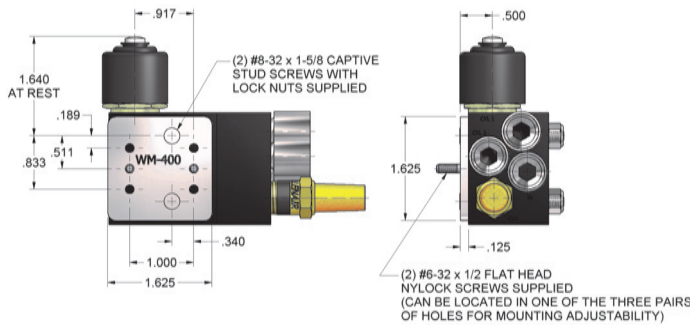

### BM-400 BASE MOUNTING

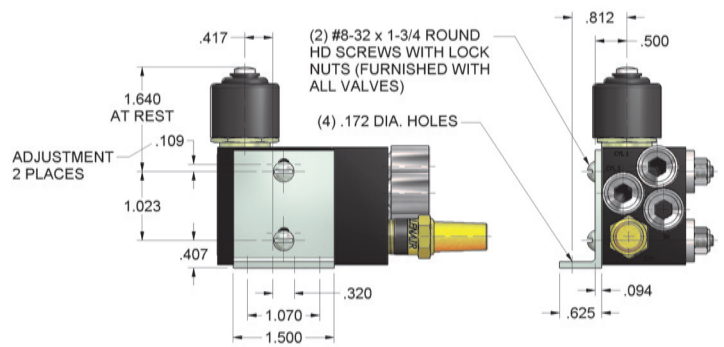

### HM-400 WALL MOUNTING, HEAVY-DUTY

Matches high capacity (Micro®-type F) electric switch dimensions  
When using VL400 Series (Left Hand Models) order HML-400 Bracket.

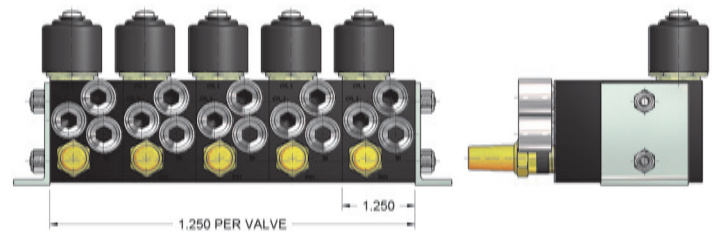
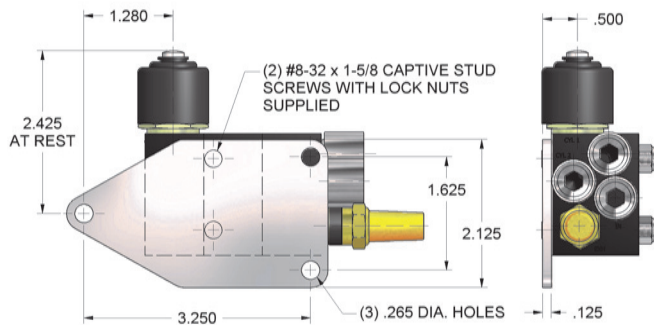

### Valve stack

Specify no. Of stations and model for each station.  
(2) BM 400 brackets & (2) #8 threaded rods with nuts furnished. Refer to BM-400 drawing for bracket dimensions and V400 drawing for other dimensions.

## OPTIONS

### VL400 STRAIGHT PLUNGER-LEFT HAND OPTION

Option available  
On all models.  
Use prefix "VL"  
To specify. Example:  
VL-400-C "Cam Roller".

OPTION PROVIDES FLUSH WALL MOUNTING WITH PORTS DIRECTED TO THE LEFT

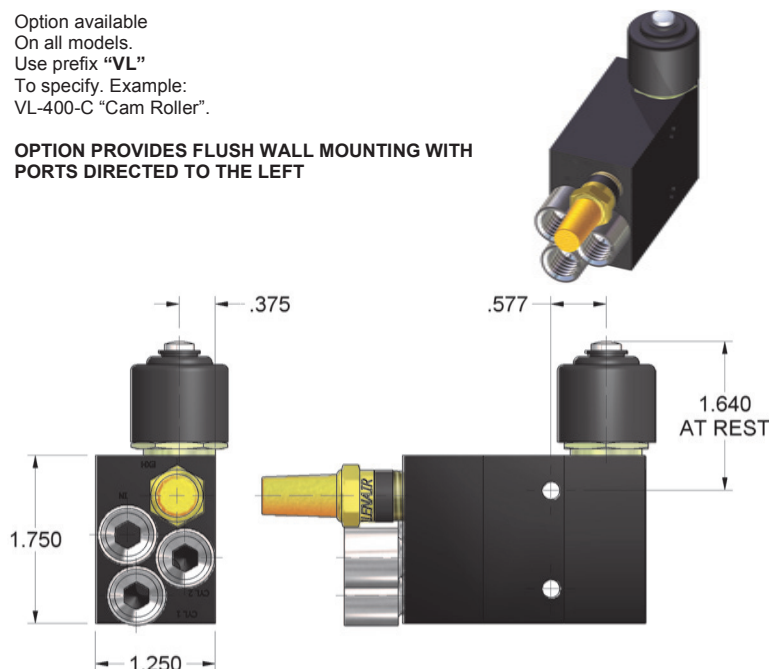

### OPTIONAL PORTING (SPECIFY WHEN ORDERING)

1/8" N.P.T. (3) 1/8 N.P.T.



### OFFSET 1/4" N.P.T.

Inlet & Cyl Port # 1 have 5° compound angle for increased separation on large piping.

